

# Builder Series



[WWW.BUILDERSERIES.COM](http://WWW.BUILDERSERIES.COM)

## FEATURES

Model #	LSS-400
Description	DOUBLE BOWL KITCHEN SINK
Material	304 STAINLESS STEEL
Color	STAINLESS STEEL
Mounting options	UNDER-MOUNT
Finish	SATIN BRUSHED
Thickness	18 GAUGE. AVAILABLE IN 16 GAUGE.
Sound proofing	SPRAY AND SOUND PAD SYSTEM
Warranty	LIMITED LIFETIME
Overflow	NO
Drain size	3 5/8", STANDARD USA, CA AND EUROPE SIZE
Certifications	CAN/CSA-B45/ANSI-A112.19/ANSI-Z124/MASS
Fits cabinet size	MADE FOR CABINETS 33" AND LARGER

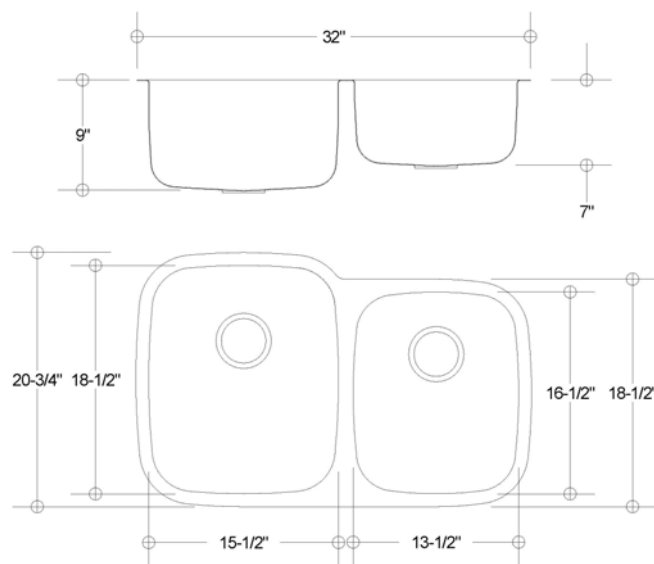

## OPTIONAL ACCESSORIES:

The following accessories are available for your sink,



## RESOURCES:

Installation instructions	<a href="http://www.specs.ctechi.com/sinkinstall.pdf">www.specs.ctechi.com/sinkinstall.pdf</a>
Cleaning instructions	<a href="http://www.specs.ctechi.com/cleaning.pdf">www.specs.ctechi.com/cleaning.pdf</a>
Warranty information	<a href="http://www.specs.ctechi.com/warranty.pdf">www.specs.ctechi.com/warranty.pdf</a>
DXF file	<a href="http://www.specs.ctechi.com/LSS-400.dxf">www.specs.ctechi.com/LSS-400.dxf</a>

For your protection and to insure the highest quality and standards, all C-TECH-I products meet or exceed one or more of the regulatory certification marks for the USA, Canada and Europe.



**C-TECH-I**  
Unique elegance and style